

AT211 Vehicle Tracking Device

User Guide



Document Version: 1.0
Device Version: 1.x
Date: July 2021

Abbreviations

ADC	Analogue to Digital Converter
ASCII	American Standard Code for Information Interchange (computer character set)
BLE	Bluetooth Low Energy
CAN	Controller Area Network
DC	Direct Current
FET	Field Effect Transistor
GIS	Geographic Information System
GNSS	Global Navigation Satellite System
GPRS	General Packet Radio Service (part of GSM)
GNSS	Global Positioning System
GSM	Global System for Mobile communication
IP	Internet Protocol (part of TCP/IP)
LED	Light Emitting Diode
MEMS	Micro Electro-Mechanical System
NMEA	National Marine Electronics Association (defined a GNSS output format)
OTA	Over the Air (remote configuration of devices)
PC	Personal Computer
PCB	Printed Circuit Board
PDU	Protocol Description Unit (describes a binary SMS format)
RFID	Radio Frequency Identification
SIM	Subscriber Identity Module
SMS	Short Message Service
SMSC	Short Message Service Centre
SV	Satellite Vehicle
TCP	Transmission Control Protocol (part of TCP/IP)
UDP	User Datagram Protocol
WGS84	World Geodetic System 1984 (global co-ordinate system used by GNSS)

Product Overview

The AT211 is simple vehicle tracking device, housed in a sturdy plastic enclosure, sealed to IP67 specifications and designed for plant & machinery applications. Both GNSS and mobile communications antennas are internal, with the option to use an external GNSS antenna when the device cannot be mounted in a location with good sky visibility. The AT211 incorporates the very latest technology, including a Cortex M4 low-power series ARM processor, Quectel BG600L-M3 GSM / LTE-M / NB2 modem and Quectel LG77L GNSS with support for GPS, GLONASS, GALILEO and Beidou. The AT211 operates from an external DC voltage source and has a 450mAh internal back-up battery, which allows operation for approx. 8 hours in continuous mode. Interconnections are made with a single 9-way DSUB connector which provides IP67 sealing when mated.

Features

The main features of the AT211 are highlighted below:

- Compact size (approximately cigarette box dimensions)
- IP67 sealing
- Cortex M4 Low-Power Series ARM Processor
- BLE 4.2 Communications (option)
- Quectel LG77L GNSS, based on MT3333 chipset
- Quectel BG600L-M3 Communications, supporting LTE Cat M1, GSM 2G and NBIoT
- Internal mobile communications antenna, ceramic PIFA type
- Internal GNSS antenna, 25mm ceramic patch (optional external antenna)
- Low power consumption (near zero current drain when vehicle ignition is off)
- 3 axis accelerometer (2/8g)
- 2 digital inputs
- 2 digital outputs
- RS232 Port
- Internal back-up battery, lithium, 450mAh
- Configuration by RS232, SMS or TCP/UDP
- Fast and reliable over the air firmware update
- Modular communications protocol X
- TCP or UDP mode
- Non-volatile storage for 2000 reports
- Pass through data mode
- SDK available for rapid development of client customised applications
- Tested and approved to: ETSI EN 301 489-1 V2.2.1: 2019

Technical Specifications

GSM-EGPRS / LTE Cat M1 / Cat NB2 Communication

Communications Module:	Quectel BG600L-M3
GSM EGPRS Frequency Bands:	850/900/1800/1900 MHz
LTE Cat M1 Frequency Bands:	B1/B2/B3/B4/B5/B8/B12/B13/B14/B18/B19/B20/B25/B26/B27/B28/B66/B85
Cat NB2 Frequency Bands:	LTE-FDD: B1/B2/B3/B4/B5/B8/B12/B13/B18/B19/B20/B25/B26/B28/B66/B71/B85
GSM Antenna:	Internal PIFA PCB trace
Data Transfer Modes:	TCP or UDP

GNSS Location

GNSS Antenna:	Internal 25 x 25 x 4mm ceramic patch
GNSS Receiver:	Quectel LG77L (MT3333 chipset)
L1/B1 Receiver:	GPS L1 C/A: 1574.397-1576.443 MHz GLONASS L1: 1597.781-1605.656 MHz BeiDou B1 C/A: 1559.052-1563.144 MHz
Position Accuracy:	< 2.5m CEP @ -130dBm
Receiver Sensitivity:	-166dBm (GPS + GLONASS, tracking & navigation)
TTF: Cold start	< 15 sec (average) @ -130 dBm
Hot start	< 2 s (average) @ -130 dBm

BLE

Version:	4.2
Antenna:	Internal

Power

External Voltage Source:	5 – 60 VDC (65.0V absolute maximum)
Internal Battery:	3.7V, 450mAh
Battery Life:	8 hours continuous operation 7 days operation in low-power mode @ 1 hour reporting 25 days operation in low-power mode @ 1 day reporting
Current Consumption, max:	300mA @ 13.8 VDC (battery charging at max. rate)
Current consumption, average:	25mA @ 13.8 VDC (typical)
Current consumption, sleep:	< 100uA

Features

Configuration:	Astra Generic Configuration commands over SMS / TCP / RS232
Firmware update:	Supports Firmware Update Over-The-Air (FOTA)
Memory:	Total 1024k on-board non-volatile flash memory
Report storage:	6000 reports
Communication Protocol:	Astra Telematics Modular Protocol X via TCP / UDP sockets

Interconnections

	2 digital pull-up inputs 2 digital outputs, 60V, 0.5A maximum, open drain 1-wire (Dallas) 1 RS232 serial port (TTL levels optional)
SIM:	Micro SIM 3FF Format, push-push style
POWER & DATA:	Molex MicroFit 3.0, dual row, 16-way male

Hardware Description

Weight 55g
Overall Dimensions 77 x 69 x 31 mm

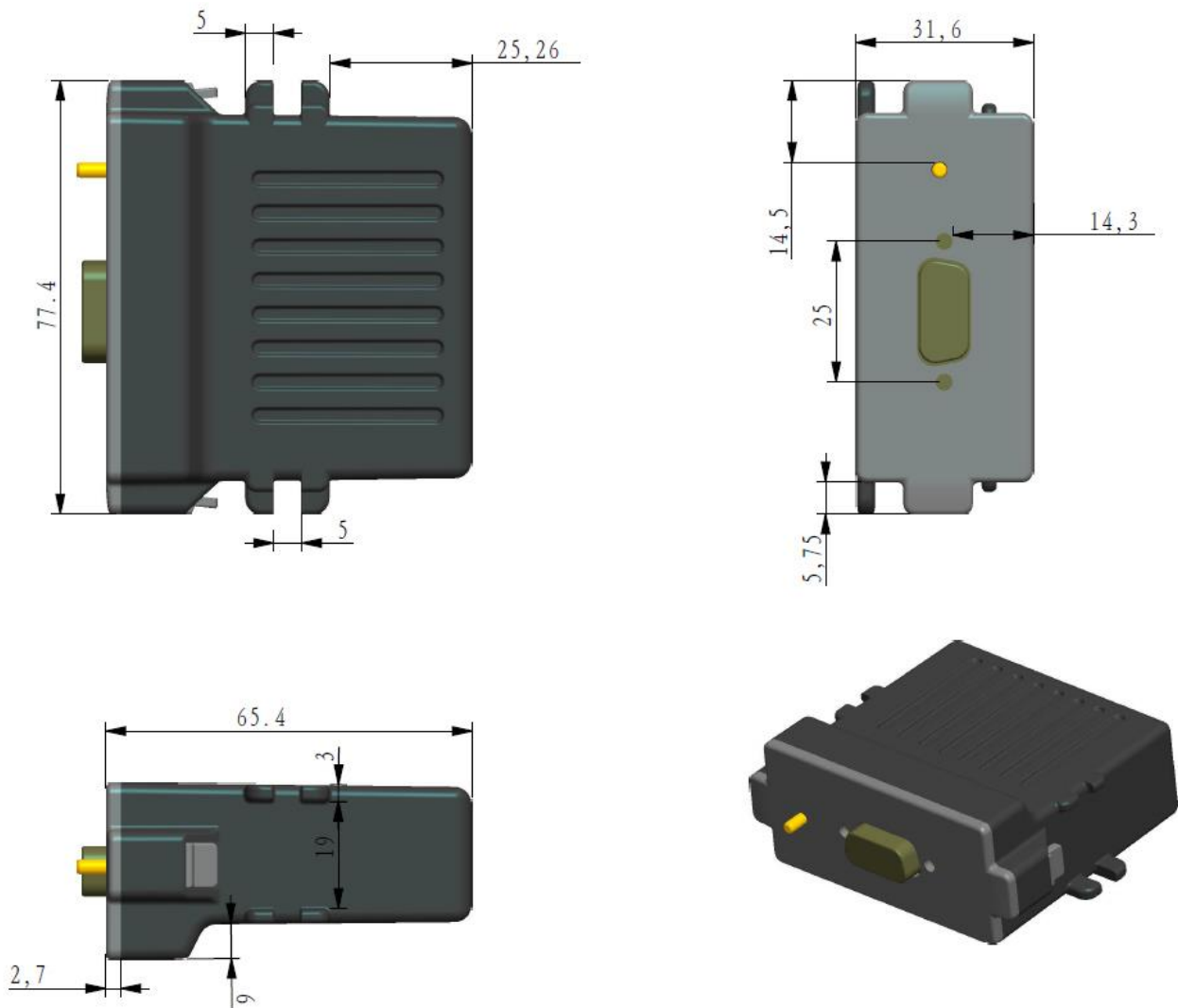

Back-up battery

Each AT211 is supplied with a 510mAh back-up battery, which is fixed to the PCB and connected as shown below:



SIM installation

Note that the AT211 powers up when the SIM is fitted



Notched corner here

Basic electrical connections

A permanent connection to +12V/+24V vehicle power should be provided to the AT211 using the RED and BLACK wires, via a 1A fuse. If using a wired ignition-sense, connect this to digital input 1, again we recommend the use of a 1A fuse:

- i. RED +12 / +24V 1A FUSED
- ii. BLACK GROUND 1A FUSED
- iii. WHITE IGNITION 1A FUSED

All unused wires should be insulated to avoid undesired behaviour.

For a full table of AT211 connections please see page 8.

Power requirements

The AT211 operates from a DC Voltage between 6 and 60 Volts. We recommend that a permanent 'live' power source is used to supply the AT211. If current drain is of concern, please see the power-down option of the \$IGNM command, which can be used to minimise battery drain when vehicles may be stationary for long periods.

External GNSS antenna (optional)

The AT211 has an internal GNSS antenna, so an external antenna is not required in most cases, but if the device is mounted in a location with poor sky visibility, an external antenna can be used. If this is required, remove the cover from the GNSS antenna connector (adjacent to the DB9) and plug in the AE004 GNSS active patch antenna.



External GNSS antenna

Status LEDs

The AT211 has internal status LEDs as below:



Mobile network communication status (BLUE)

GNSS fix status (GREEN)

GNSS Status (green):	Constant ON Double Flash @ 1Hz Slow Flash @ 0.2Hz	Searching for initial fix GPS 3D navigation Lost GPS navigation
COMM Status (blue):	200 ms ON / 1800 ms OFF 1800 ms ON / 200 ms OFF Constant OFF	ON / SEARCHING registered on network Modem OFF

During normal operation the LEDs should appear as below:

GNSS	double flash once per second
GSM	stays ON and blinks OFF every 2 seconds

Enclosure Sealing

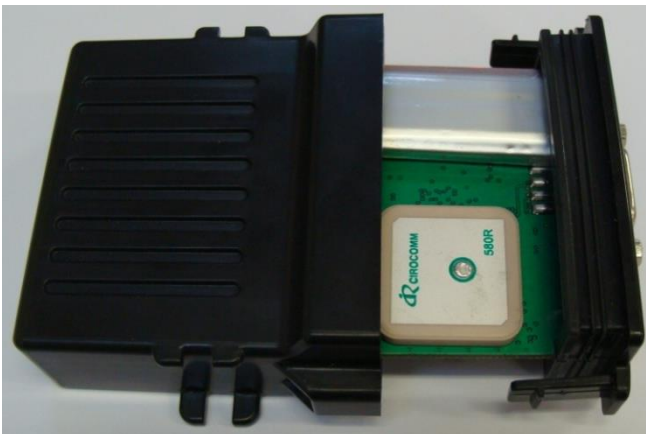

When fitting the enclosure cover, please ensure that both clips are snapped into place to guarantee IP67 sealing. Note that the GNSS antenna faces the top of the enclosure (with the slots). Ensure that the PCB is aligned with the guide slots inside the enclosure and carefully push in until the clips are fully engaged.

Note that the enclosure keeps the SIM in place



Also ensure that the protective cap is fitted to The GNSS antenna connector when the external antenna option is not used

Mounting



The AT211 can be secured to a flat surface with double sided foam adhesive tape, screwed in place using the two mounting lugs or secured with a single cable tie (up to 5mm width).

Interconnections

All connections to the AT211 are provided by a single DB9 cable assembly.

AT211 Pin Applications and Colour Code

Pin	Function	Wire colour
1	VIN 7 - 36 VDC	red
2	RS232-TX1	green
3	RS232-RX1	blue
4	DIG-OUT1	yellow
5	GND	black
6	DIG-OUT2	pink
7	DIG-IN1	white
8	DIG-IN2	brown
9	IBUTTON	grey

Digital Inputs

Digital inputs 1 and 2 are normally-low and can be connected directly to 12/24V vehicle circuits (i.e. power take off).

Digital Outputs

The AT211 is capable of switching two external loads of up to 60V, 0.5A using MOSFET low side switches, which must be used to switch the GND side of the load. The use of a 1A in-line fuse with these switches is essential to prevent any damage through fault scenarios.

Integrated Accelerometer

The AT211 has a built in 3 axis MEMS accelerometer that operates in the range $\pm 2g$ and is used to measure driver behaviour (acceleration and braking) during normal driving conditions.

The accelerometer also allows the AT211 to wake from sleep on movement, with configurable thresholds. Please refer to the \$MEMS parameter for more details.

iButton (Dallas Key) Interface

This can be used to read iButton devices for the purpose of Driver Identification. See the Driver ID Application Note for more details of how to use this feature.

BLE (Bluetooth Low-Energy)

The AT211 comes with the option of BLE communications, which can be used to send commands and receive replies via a mobile smartphone app. This can be a useful backup for controlling the immobiliser during mobile network communication outages.

Configuration

The AT211 shares a common set of configuration commands with our other devices. Please refer to our Generic Device Configuration Reference for details.

Electrical Parameters

Operating Conditions

Parameter	Min	Max	Units
Power Supply Input Voltage	+6	+60	V
Digital Input High Voltage Threshold	+5.0	-	V
Digital Input Low Voltage Threshold	-	+2.0	V
Digital Maximum Voltage	-	+30.0	V
Digital Maximum Current	-	0.5	A

Absolute Maximum Ratings

Parameter	Min	Max	Units
Power Supply Input Voltage	-32	+65	V
Voltage on RS232 RX	-25	+25	V
Voltage on RS232 TX	-13	+13	V
Voltage on iButton/Dallas Interface	-5	+5	V
Current sunk by MOSFET low side switches		500	mA
Voltage rating of MOSFET switches	-	+60.0	V
Storage Temperature	-40	+85	°C
Operating Temperature (without battery)	-20	+60	°C
Operating Temperature (with battery)	0	45	°C

Typical Power Consumption

Operating Mode	Current @ 13.8V	Current @ 27.6V	Power Consumption
Fully Operational	25mA	14mA	< 400mW
Battery charging	500mA	275mA	< 7W
Sleep (no battery)	0.5mA	0.3mA	7mW
Sleep (with battery)	< 10uA	< 10uA	0.1mW

Environmental Specifications

Parameter	Specification
Storage temperature	-40 to +85 °C
Operating temperature (no battery)	-20 to +60 °C
Operating temperature (with battery)	0 to +45 °C (note: no charging below 0°C)
Ingress Protection	IP67 (dustproof and waterproof to 1m*)
Vibration, broadband random	Complies with IEC60068-2-64
Shock	Complies with IEC60068-2-64
Humidity	Complies with IEC60068-2-64

* Conditions as per DIN VDE 0470 PART 1 / EN 60 529 / IEC 529