

AT900 Self-Install, 2-Wire Tracking Device

User Installation Guide



| | |
|--------------------------|------------|
| Document Version: | 1.1 |
| Device Hardware Version: | 1.0 |
| Date: | March 2026 |

Product Overview

The AT900 is low-cost vehicle tracking device, housed in a compact IP67 enclosure, designed for direct connection to the vehicle battery for a simple self-installation. The AT900 features dual band GNSS (L1 + L5) for ultimate sensitivity and effective performance when the device is mounted under the vehicle bonnet (i.e. in the engine bay area). Mobile network communications are LTE Cat 1 (4G) with 2G fallback. The AT900 has a 170mAh internal back-up battery, allowing operation for approx. 5 hours in continuous mode, or 8 days in low-power mode (daily update). Ignition mode detection is achieved automatically by monitoring the battery float charging voltage whilst the vehicle engine is running. Vehicle battery drain is avoided by auto-power-down when the vehicle engine is not running.

Features

The main features of the AT900 are highlighted below:

- Compact size
- Dual Band (L1 + L5) GNSS
- Quectel EG915U-EU LTE Cat 1 (4G) + 2G mobile communications
- Internal GSM and LTE antenna
- Internal GNSS antenna, 25mm ceramic patch
- Low power consumption (near zero current drain when vehicle ignition is off)
- 3 axis accelerometer (2/8g)
- BLE for use with external sensors or immobiliser relay
- Internal back-up battery, lithium-polymer, 170mAh
- Configuration by USB-C, SMS or TCP/UDP
- Fast and reliable over the air firmware update
- Modular communications protocol X
- TCP or UDP mode
- Non-volatile storage for 2000 reports
- SDK available for rapid development of client customised applications
- Approved to: CE & UKCA

Device Preparation & Installation

1. SIM Installation

AT900 devices are typically shipped with the SIM installed, ready for installation. In case you receive the devices without SIM pre-installed, fit a 4FF nano SIM into the hinged SIM holder. Place the SIM as below, fold over the cover and gently slide to the left to lock into place:

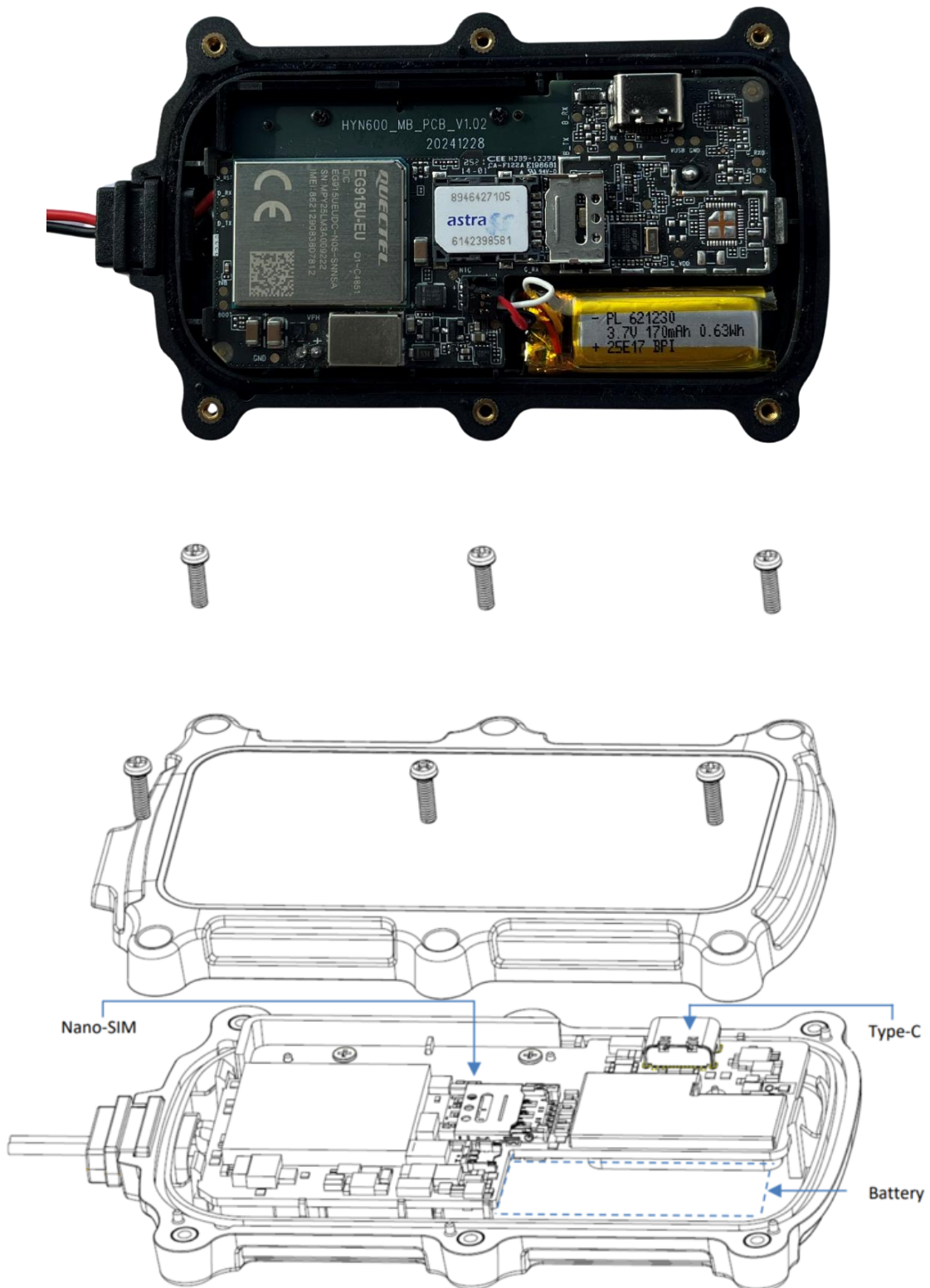

2. Connect the back-up battery

Check that the battery is connected. If necessary, gently press the connector directly down onto the mating header on the PCB:



3. Configuration / Diagnostics via USB-C

If you need to review / check device configuration, connect the AT900-specific USB-C / USB-A cable. The USB-C side connects to the device and the USB-A to a PC. On the PC, open an ASCII terminal (e.g. TeraTerm or PuTTY) with serial connection @ 115200 baud.

Refer to *Astra Telematics Device Configuration Guide – Generic Command Reference* for details of configuration options and commands.

4. Replace the Enclosure Cover

Replace the enclosure cover and secure with 6 x M2 screws using a torx T6 driver. Torque to 35cNm

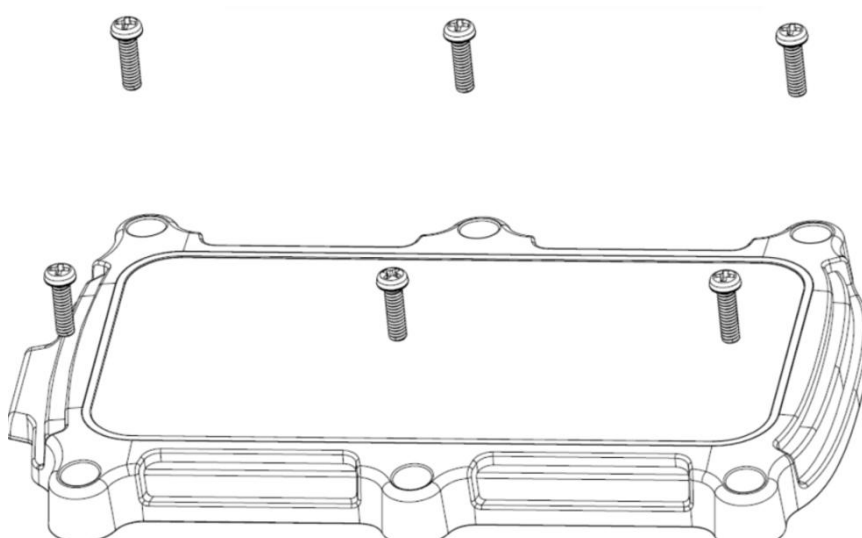

5. Status LEDs

| | | |
|----------------------|--|---|
| GNSS Status (GREEN): | Constant ON Double Flash @ 1Hz Slow Flash @ 0.2Hz Rapid Flashing (>2Hz) | Searching for initial fix GNSS 3D navigation Lost GPS navigation TEST MODE |
| COMM Status (BLUE): | 200 ms ON / 1800 ms OFF 1800 ms ON / 200 ms OFF Constant OFF | ON / SEARCHING registered on network Modem OFF |
| Power Status (RED): | OFF 200ms ON / 800ms OFF | Powered-off or sleep mode Powered-on / awake |

6. Battery Power Connection

A permanent connection to +12V/+24V vehicle power should be provided to the AT900 using the RED and BLACK wires. The recommended technique for petrol, diesel or hybrid vehicles is to connect directly to the vehicle battery:

| | |
|-------|-------------|
| RED | +12V / +24V |
| BLACK | GROUND |

The AT900 device is internally fused.

7. Device Mounting

- 7.1 Clean the top of the vehicle battery using the IPA wipe (supplied)
- 7.2 Attach the AT900 to the battery using the double-sided adhesive pad (supplied)

NOTE: Fix the AT900 device with the label side should facing up

- 7.3 Tidy the cables and secure with the cable tie (supplied)

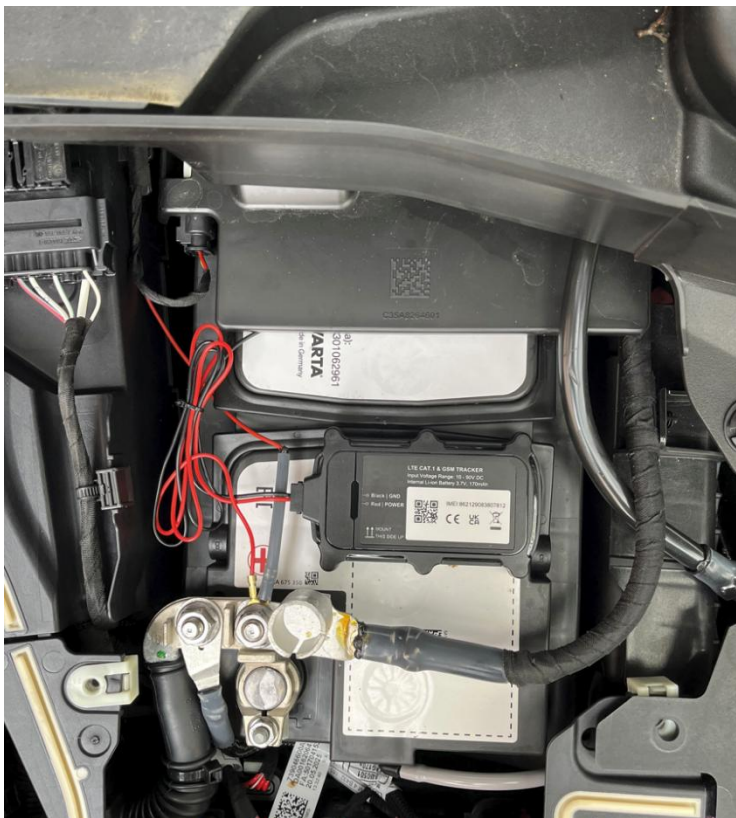

8. Ignition Detection

The AT900 detects ignition / engine running status automatically from the battery voltage, wakes when the vehicle starts. When the vehicle is parked (engine not running), the device will power-down to avoid drain on the vehicle battery.

Electrical Parameters

Operating Conditions

| Parameter | Min | Max | Units |
|----------------------------|-----|-----|-------|
| Power Supply Input Voltage | +7 | +90 | V |

Absolute Maximum Ratings

| Parameter | Min | Max | Units |
|---|-----|-----|-------|
| Power Supply Input Voltage | -32 | +95 | V |
| Storage Temperature | -40 | +85 | °C |
| Operating Temperature (without battery) | -20 | +60 | °C |
| Operating Temperature (with battery) | 0 | 45 | °C |

Typical Power Consumption

| Operating Mode | Current @ 13.8V | Current @ 27.6V | Power Consumption |
|----------------------|-----------------|-----------------|-------------------|
| Fully Operational | 25mA | 12mA | < 350mW |
| Battery charging | 100mA | 55mA | < 1.5W |
| Sleep (with battery) | < 10uA | < 10uA | 0.1mW |

Environmental Specifications

| Parameter | Specification |
|--------------------------------------|---|
| Storage temperature | -40 to +85 °C |
| Operating temperature (no battery) | -20 to +60 °C |
| Operating temperature (with battery) | 0 to +45 °C (note: no charging below 0°C) |
| Ingress Protection | IP67 |
| Vibration, broadband random | Complies with IEC60068-2-64 |
| Shock | Complies with IEC60068-2-64 |
| Humidity | N/A |